

COMPACT

Cylinders UNITOP



Find out our
key products



Solution for most applications



Easy and intuitive choice



Excellent value for money



Wide availability



Fast delivery



Features and certifications

Series of compact cylinders conforming to European UNITOP standards. The barrel with grooves allows the mounting of magnetic reed switches directly in the tube without brackets. Available in bores from Ø 12 to 100, single acting or double acting, magnetic, with elastic dampers on the piston. Supplied as standard in compliance with Reach and RoHS directives, and SIL certificated. On request, they can be also supplied according to the 2014/34/EU ATEX Directive.



Type CS Ø 12 ÷ 100 from page 1.17.20



Compact cylinders conforming to European UNITOP standards, available in bores from Ø 12 to 100, single acting, magnetic with elastic dampers on piston. Barrel with grooves allows mounting of magnetic reed switches directly, not protruding beyond the profile of the cylinder.

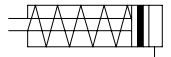

Type CD Ø 12 ÷ 100 from page 1.17.20



Compact cylinders conforming to European UNITOP standards, available in bores from Ø 12 to 100, double acting, magnetic with elastic dampers on piston. Barrel with grooves allows mounting of magnetic reed switches directly, not protruding beyond the profile of the cylinder.

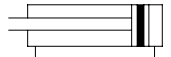

Options		
Description	Symbol	Suffix
Anti-rotating plate (available only for CD type, from Ø 16)		N
Rear spring (available only for CS type)		T
Male threaded rod		M
Through rod		P
FKM seals	-20°C ÷ +150°C 	V
ATEX versions on request		/ATEX
Special versions on request		/S

The options, when this is possible, can be combined with each other. For options matching see from page 1.17.4; For code key see from page 1.17.5

Options matching

Series	Bore	Model	Standard options matching					
			N (Ø16÷100)	T	M	P	V	/ATEX
CS	Ø 12 ÷ 100	Standard	-	●	●	●	●	●
		Rear spring (T)	-		●	-	●	●
		Male threaded rod (M)	-	●		● ¹	●	●
		Through rod (P)	-	-	● ¹		●	●
CD	Ø 12 ÷ 100	Standard	●	-	●	●	●	●
	Ø 16 ÷ 100	Anti-rotating plate (N)		-	● ¹	●	●	●
	Ø 12 ÷ 100	Male threaded rod (M)	● ¹	-		● ¹	●	●
		Through rod (P)	●	-	● ¹		●	●

Key

● allowed matching; - not allowed matching

Options matching - notes

(1) The male threaded rod (option **M**) in combination with through rod (option **P**) is applied on both sides of rod, except when combined with the anti-rotation plate (option **N**), in which case the male rod will only be applied on the side opposite the plate.

Standard materials

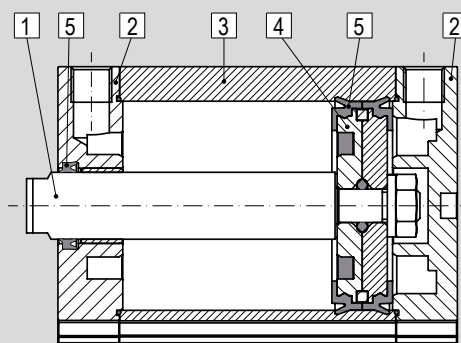

Position	Description	Materials
1	Rod	Stainless Steel AISI 304
2	Heads	Anodised aluminium
3	Tube	Anodised aluminium
4	Piston	Aluminium
5	Seals	NBR / Polyurethane (PU)
-	Anti-rotating plate (option N)	Anodised aluminium

Code key

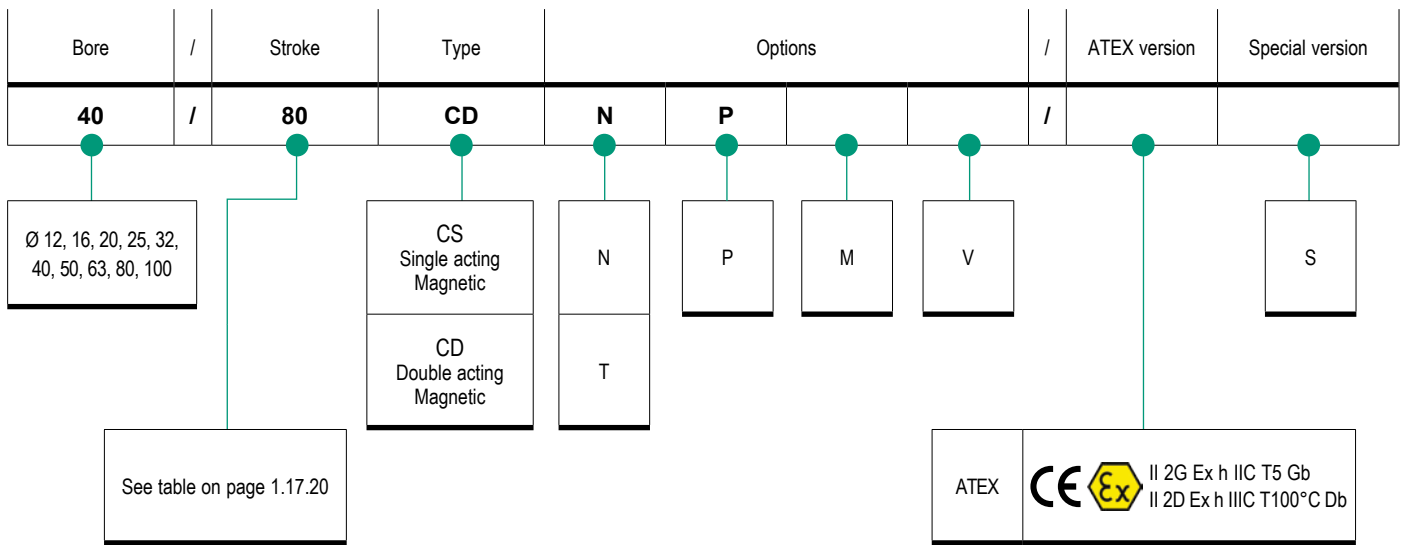

How to order

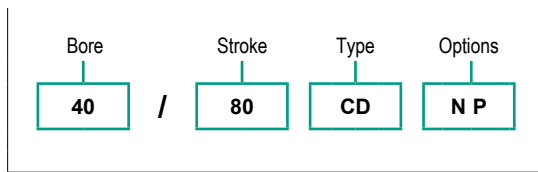

Notes

Options in the same grid are alternative to each others.
 For further information on options and their matching, see page 1.17.3 and page 1.17.4
 For further information on the ATEX 2014/34/EU Directive, on classifications and protections, see from page III.1

Standard* seal kit

Number of components	Description
n. 1	Rod seal
n. 2	Tube-head o-ring
n. 2	Piston seal

*For cylinders with option P, the kit include further components

Standard seal kit code key

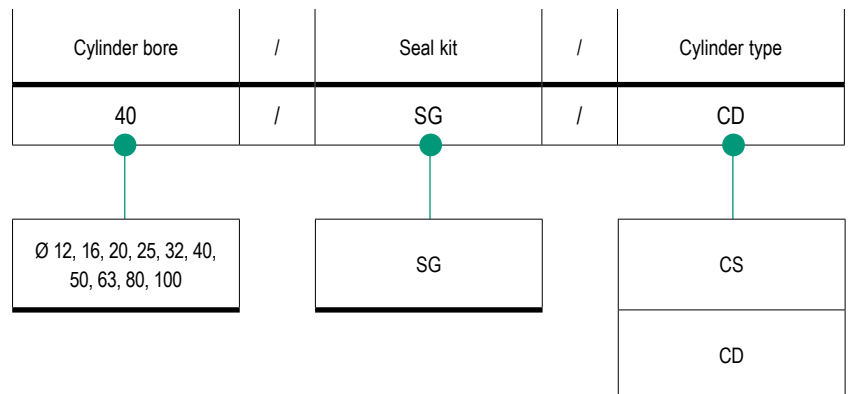

Accessories

1 - CYLINDERS

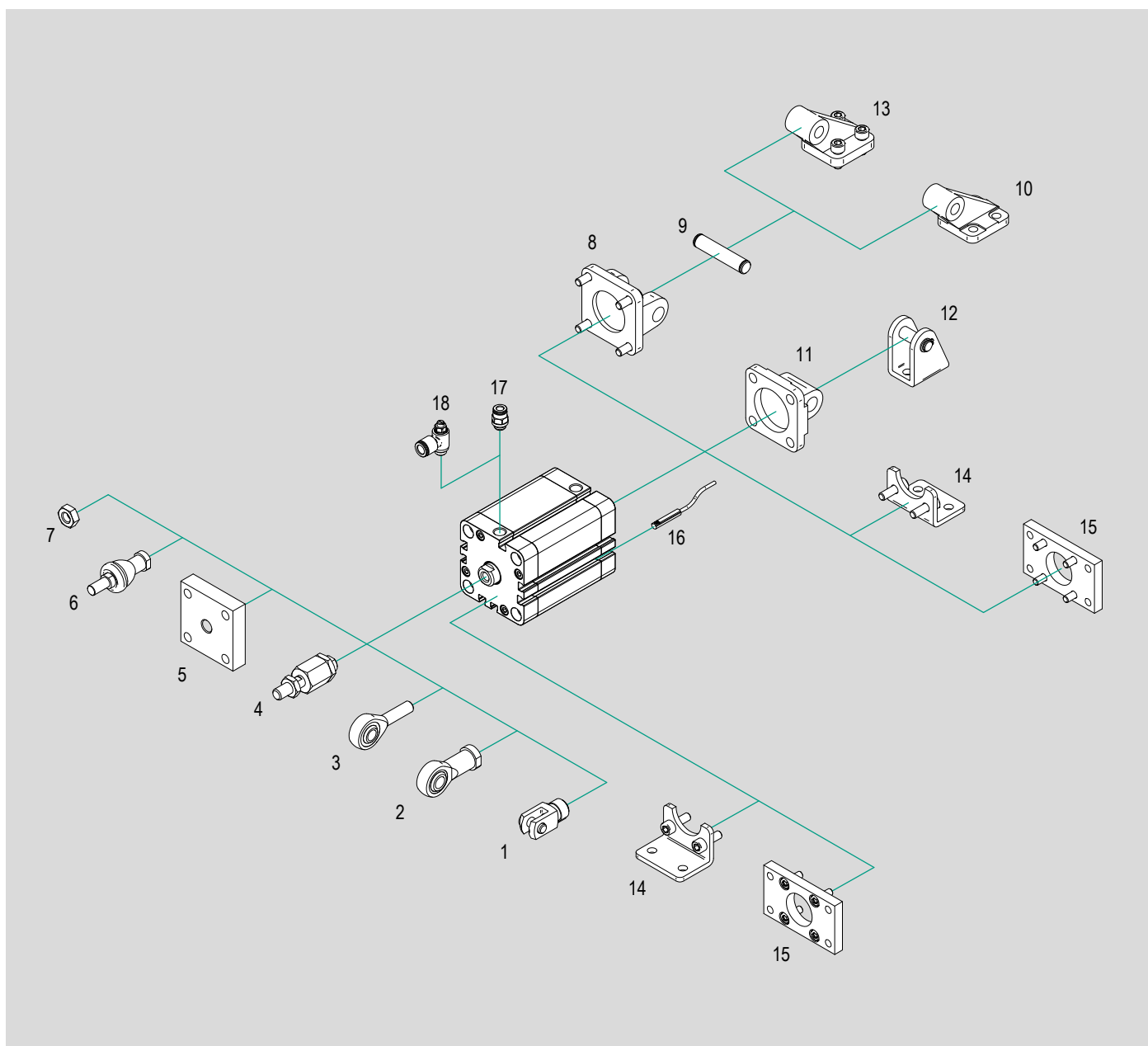

N.	Cylinder bore	Item	Description	Compliance	Matching		Code page	Data sheet page
					CS	CD		
1	Ø 12 ÷ 100	FF..ISO	ISO female clevis with clip	ISO 8140	● ⁽¹⁾	● ⁽¹⁾	1.17.90	1.85.10
	Ø 16 ÷ 100	FFP..ISO	ISO female clevis with pin and seeger		● ⁽¹⁾	● ⁽¹⁾		
	Ø 12 ÷ 100	FFN..ISO	ISO female clevis (body only)		● ⁽¹⁾	● ⁽¹⁾		
2	Ø 12 ÷ 100	RF..SE	Bearing head (DIN 648K) with female thread	ISO 8139	● ⁽¹⁾	● ⁽¹⁾	1.17.90	1.90.1
3	Ø 16 ÷ 100	RM..SE	Bearing head (DIN 648K) with male thread		●	●		
4	Ø 12 ÷ 100	GB..	Bearing - Self-aligning articulated coupling	-	● ⁽¹⁾	● ⁽¹⁾	1.17.91	1.90.10
5	Ø 16 ÷ 100	GC..	Self-aligning coupling		● ⁽¹⁾	● ⁽¹⁾		
6	Ø 12 ÷ 100	RBI..	Bearing - Axial articulated coupling		● ⁽¹⁾	● ⁽¹⁾		
		RBL..	Bearing - Angular articulated coupling	● ⁽¹⁾	● ⁽¹⁾			
7	Ø 12 ÷ 100	D..	Rod nut	UNI 5589	● ⁽¹⁾	● ⁽¹⁾	1.17.90	1.90.70
8	Ø 32 ÷ 100	CF..ALUN	Rear clevis	UNITOP	●	●	1.17.91	1.100.100
		CF..AQUN			●	●		1.100.150
9	Ø 32 ÷ 100	SEC..AQIS	Pin for rear clevis	UNITOP	●	●	1.17.92	1.98.5
10	Ø 12 ÷ 25	CM..ALUN	Rear eye		●	●	1.17.91	1.100.100
	Ø 20 ÷ 25	CM..AQUN			●	●		1.100.150
11	Ø 32 ÷ 100	CM..ALIS		ISO MP4	●	●		1.100.102
		CM..AQIS	●		●			
12	Ø 12 ÷ 25	CF..+P	Rear 90° hinge	ISO MP3	●	●	1.17.92	1.100.153
13	Ø 32 ÷ 100	ASV..ALIS	Rear 90° hinge	ISO AB7 CETOP RP 107P	●	●		1.100.102
		ASV..AQIS		●	●	1.100.153		
14	Ø 12 ÷ 100	PB..AQUN	Low foot	UNITOP	●	●	1.17.91	1.100.152
15	Ø 12 ÷ 100	FLV..ALUN	Flange		●	●		1.100.101
		FLV..AQUN		●	●			
16	Ø 12 ÷ 100	ASV..	Magnetic reed switch T groove	-	●	●	1.17.92	1.110.10
		MK..	ATEX magnetic reed switch T groove	2014/34/EU	●	●		1.113.1
17	Ø 12 ÷ 100	R..	Push-in fittings	-	●	●	4.2.1	
18	Ø 12 ÷ 100	V..C	Flow controls, for cylinders		●	●	4.94.1	

Key

● matching accessory; - not matching accessory

(1) Matching only with option **M**

Main features

12 ÷ 100

Bores Ø

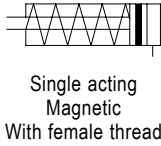

Single acting
Magnetic
With female thread

CS

Type



12 ÷ 100

Bores Ø

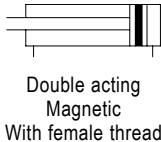

Double acting
Magnetic
With female thread

CD

Type



Technical data

Bore Ø mm	12	16	20	25	32	40	50	63	80	100	
Fluid	Filtered compressed air with or without lubrication. Lubrication, if started, must be continued.										
Pressure range	2 ÷ 10 bar										
Temperature range	-30°C ÷ +80°C (standard)					-20°C ÷ +150°C (V)					
Port	M5				1/8"				1/4"		
Grooves for switches	3						7				
Thrust force (N)*	59	110	177	270	448	700	1125	1800	2900	4510	
Spring traction force (N)*	6		7	12	16	23	30	35	60	100	
Strokes**	CS	5 ÷ 60 mm						10 ÷ 60 mm			
	CD	5 ÷ 100 mm	5 ÷ 125 mm	5 ÷ 160 mm	5 ÷ 200 mm		5 ÷ 250 mm	10 ÷ 250 mm			
Rod thread	CS-CD	M3	M4	M5	M6		M8		M10	M12	
	CSM-CDM	M6	M8	M10x1,25			M12x1,25		M16x1,5	M20x1,5	

*For cylinders CS type; **With option N, in Ø 20 maximum stroke is 125 mm

Standard strokes

Stroke mm	CS Bore Ø mm									
	12	16	20	25	32	40	50	63	80	100
5										
10										
15										
20										
25										
30										
40										
50										
60										

Stroke mm	CD Bore Ø mm									
	12	16	20	25	32	40	50	63	80	100
5										
10										
15										
20										
25										
30										
40										
50										
60										
80										
100										
125										
160										
200										
250										

Key
 Standard stroke

Standard dimensions

Type: **CS-CD**
Ø 12 ÷ 25

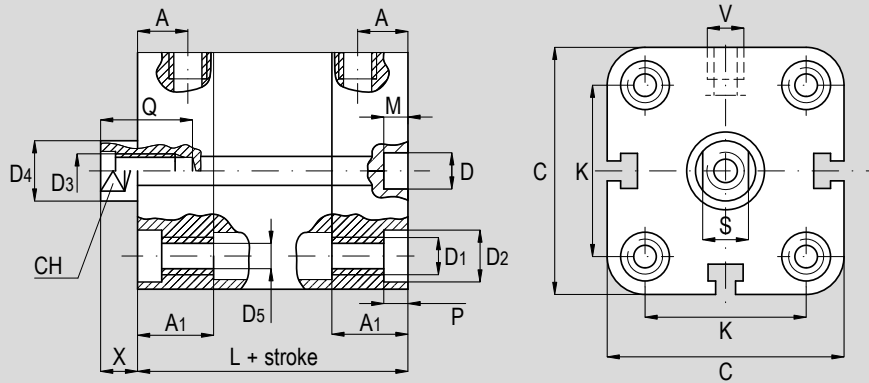

Type: **CS-CD**
Ø 32 ÷ 100

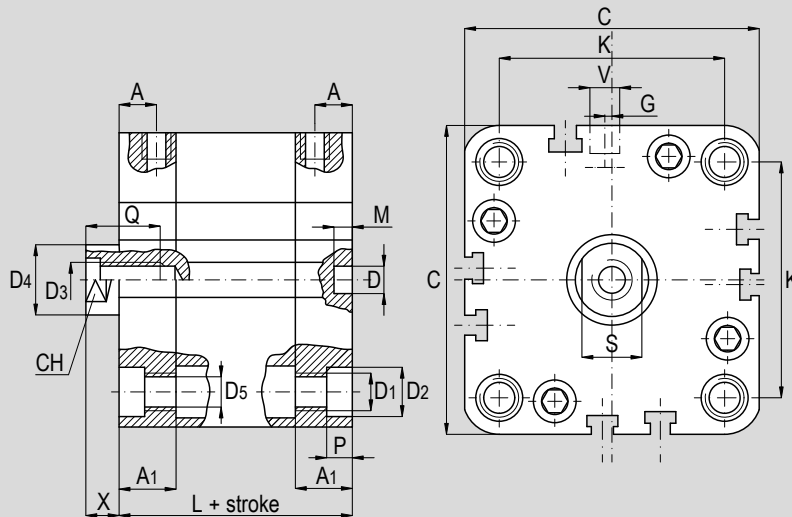

Ø (mm)	C	CH	D Ø	D ₁ Ø	D ₂ Ø	D ₃ Ø	D ₄ Ø	D ₅ Ø	G	V	A	A ₁	K	S	P	M	Q	X	L
12	29	5	6	M4	6	M3	6	3,3	-	M5	8	12,25	18	5	3,5	4	8	4,5	38 ⁽¹⁾
16	29	6	6	M4	6	M4	8	3,3	-	M5	8	12,25	18	6	3,5	4	11	4,5	38 ⁽¹⁾
20	36	8	6	M5	7,5	M5	10	4,2	-	M5	8	12,25	22	8	4,5	4	12	4,5	38 ⁽¹⁾
25	40	8	6	M5	7,5	M5	10	4,2	-	M5	8	12,75	26	8	4,5	4	12	5,5	39,5 ⁽²⁾
32	50	10	6	M6	9	M6	12	5,2	4	1/8"	8	14,5	32	10	5,5	4	15	6	44,5 ⁽²⁾
40	58	10	6	M6	9	M6	12	5,2	3	1/8"	8	14,75	42	10	5,5	4	15	6,5	45,5 ⁽²⁾
50	67	13	6	M8	10,5	M8	16	6,7	-	1/8"	8	14,75	50	13	6,5	4	17	7,5	45,5 ⁽²⁾
63	80	13	8	M10	13,5	M8	16	8,5	-	1/8"	8	14,25	62	13	8,5	4	17	7,5	50 ⁽²⁾
80	100	17	8	M10	13,5	M10	20	8,5	-	1/8"	8,5	16	82	17	8,5	4	17	8	56 ⁽³⁾
100	124	22	8	M10	13,5	M12	25	8,5	-	1/4"	10,5	19,25	103	22	8,5	4	22	10	66,5 ⁽³⁾

(1) CS type, for strokes > 30 mm, add +10 mm to dimension;
 (2) CS type, for strokes > 30 mm, add +20 mm to dimension;
 (3) CS type, for strokes > 30 mm, add +30 mm to dimension.

Dimensions with options

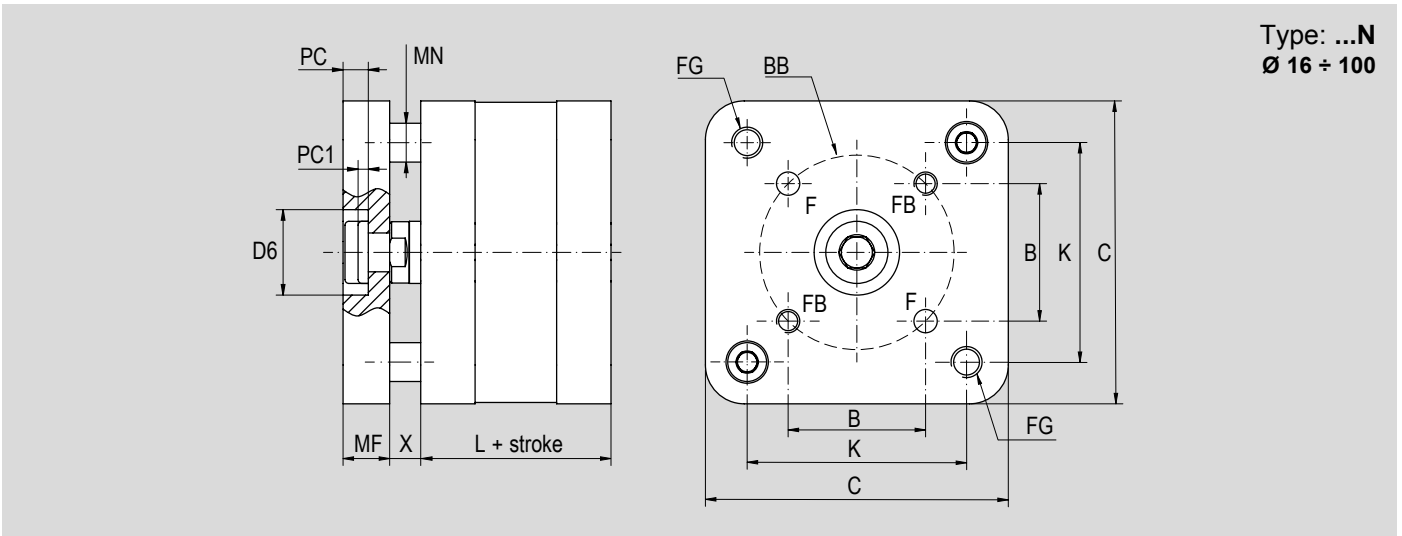
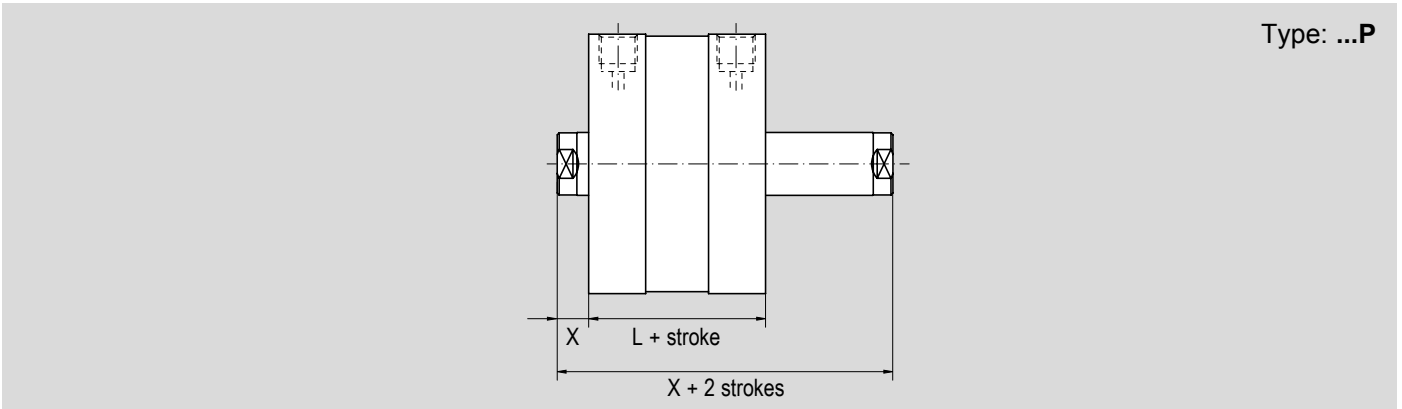
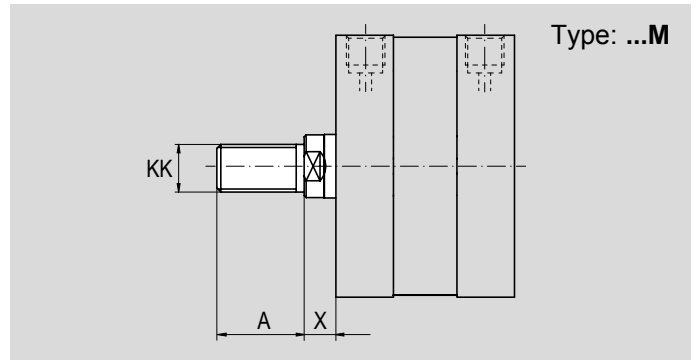
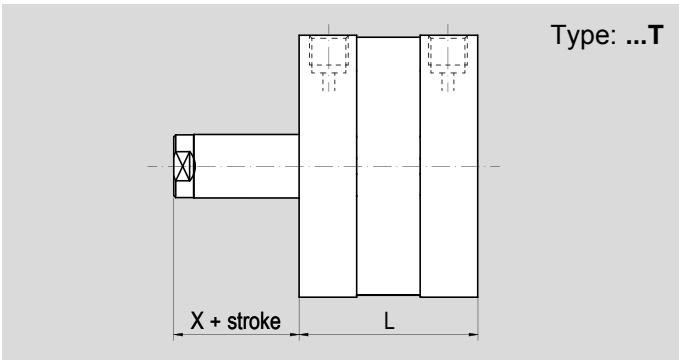

Ø (mm)	A	KK	X	L	MF +0,1	C	K	B	FG	ØBB ±0,1	ØF +0,1	FB	ØD6 h9	PC	MN f7	PC1
12	16	M6	4,5	38 ⁽¹⁾	-	-	-	-	-	-	-	-	-	-	-	-
16	20	M8x1.25	4,5	38 ⁽¹⁾	6	29	18	9,9	M5	14	3	M3	9	3,8	5	1
20	22	M10x1.25	4,5	38 ⁽¹⁾	8	36	22	12	M5	17	4	M4	11	5	5	1,5
25	22	M10x1.25	5,5	39,5 ⁽¹⁾	8	40	26	15,6	M5	22	5	M5	14	5	6	1,5
32	22	M10x1.25	6	44,5 ⁽¹⁾	10	50	32	19,8	M6	28	5	M5	17	6,5	8	2,5
40	22	M10x1.25	6,5	45,5 ⁽¹⁾	10	58	42	23,3	M6	33	5	M5	17	6,5	10	2,5
50	24	M12x1.25	7,5	45,5 ⁽¹⁾	12	67	50	29,7	M8	42	6	M6	22	7,5	10	2,5
63	24	M12x1.25	7,5	50 ⁽¹⁾	12	80	62	35,4	M10	50	6	M6	22	7,5	10	2,5
80	32	M16x1.5	8	56 ⁽²⁾	14	100	82	46	M10	65	8	M8	28	9	14	3
100	40	M20x1.5	10	66,5 ⁽²⁾	14	124	103	56,6	M10	80	10	M10	30	10	14	3

(1) CS type, with option T, for strokes > 30 mm, add +10 mm to dimension;
(2) CS type, with option T, for strokes > 30 mm, add +20 mm to dimension;

Female clevis with clip FF..ISO

	For cylinder Ø mm	Code	Item	Compliance
	12	041002	FF06ISO/DIN	
	16	041003	FF08ISO/DIN	
	20+40	041004	FF10ISO	
	50+63	041005	FF12ISO	
	80	041006	FF16ISO	
	100	041007	FF20ISO	

Matching with option M only

Female clevis with pin and seeger FFP..ISO

	For cylinder Ø mm	Code	Item	Compliance
	12	-	FFP06ISO/DIN	
	16	041051	FFP08ISO/DIN	
	20+40	041051	FFP10ISO	
	50+63	041040	FFP12ISO	
	80	041013	FFP16ISO	
	100	041017	FFP20ISO	

Matching with option M only

Female clevis (body only) FFN..ISO

	For cylinder Ø mm	Code	Item	Compliance
	12	041011	FFP06ISO/DIN	
	16	041018	FFP08ISO/DIN	
	20+40	041014	FFN10ISO	
	50+63	041016	FFN12ISO	
	80	041012	FFN16ISO	
	100	041015	FFN20ISO	

Matching with option M only

Rod nut D..

	For cylinder Ø mm	Code	Item	Compliance
	12	041450	D6x1	
	16	041451	D8x1,25	
	20+40	041452	D10x1,25	
	50+63	041454	D12x1,25	
	80	041455	D16x1,5	
	100	041456	D20x1,5zB	

Matching with option M only

Bearing heads (DIN 648K) with female thread RF..SE

	For cylinder Ø mm	Code	Item	Compliance
	12	041552	RF6SE	
	16	041553	RF8SE	
	20+40	041554	RF10SE	
	50+63	041555	RF12SE	
	80	041557	RF16SE	
	100	041559	RF20SE	

Matching with option M only

Bearing heads (DIN 648K) with male thread RM..SE

	For cylinder Ø mm	Code	Item	Compliance
	16	041500	RM4SE	
	20-25	041501	RM5SE	
	32-40	041502	RM6SE	
	50+63	041503	RM8SE	
	80	041550	RM10SE/M10x1,5	
	100	041514	RM12SE/M12x1,75	

Self-aligning articulated coupling GB..

	For cylinder Ø mm	Code	Item	Compliance
	12	041702	GB010	-
	16	041703	GB020	
	20+40	041704	GB040	
	50+63	041706	GB060	
	80	041708	GB100	
	100	041709	GB120	

Matching with option M only

Self-aligning coupling GC..

	For cylinder Ø mm	Code	Item	Compliance
	20+40	041722	GCM10x1,25	-
	50+63	041723	GCM12x1,25	
	80	041724	GCM16x1,5	
	100	041725	GCM20x1,5	

Matching with option M only

Axial articulated coupling RBI..

	For cylinder Ø mm	Code	Item	Compliance
	12	041602	RBI6	-
	16	041603	RBI8	
	20+40	041604	RBI10	
	50+63	041605	RBI12	
	80	041607	RBI16	
	100	041609	RBI20	

Matching with option M only

Angular articulated coupling RBL..

	For cylinder Ø mm	Code	Item	Compliance
	12	041652	RBL6	-
	16	041653	RBL8	
	20+40	041654	RBL10	
	50+63	041655	RBL12	
	80	041657	RBL16	
	100	041659	RBL20	

Matching with option M only

Rear clevis in aluminium* CF..ALUN

	For cylinder Ø mm	Code	Item	Compliance
	32	040711	CF032ALUN	UNI TOP
	40	040712	CF040ALUN	
	50	040713	CF050ALUN	
	63	040714	CF063ALUN	
	80	040715	CF080ALUN	
	100	040716	CF100ALUN	

*Available also in steel (item CF..AQUN) in Ø 32 ÷ 100, see page 1.100.150
Pin (item SEC..AQIS) to be ordered separately, see page 1.17.110
Screws to be ordered separately, see from page 1.101.40

Rear eye in aluminium* CM..ALUN

	For cylinder Ø mm	Code	Item	Compliance
	12-16	040701	CM012/016ALUN	UNI TOP
	20	040702	CM020ALUN	
	25	040703	CM025ALUN	



*Available also in steel (item CM..AQUN) in Ø 20 ÷ 25, see page 1.100.150
Screws to be ordered separately, see from page 1.101.40

Rear eye in aluminium* with screws CM..ALIS+V

	For cylinder Ø mm	Code	Item	Compliance
	32	042061	CM032ALIS+V	ISO MP4
	40	042062	CM040ALIS+V	
	50	042063	CM050ALIS+V	
	63	042064	CM063ALIS+V	
	80	042065	CM080ALIS+V	
	100	042066	CM100ALIS+V	



*Available also in steel (item CM..AQIS+V) in Ø 32 ÷ 100, see page 1.100.154

Flange in aluminium FL..ALUN

 	For cylinder Ø mm	Code	Item	Compliance
	12-16	040721	FL012/016ALUN	UNI TOP
	20	040722	FL020ALUN	
	25	040723	FL025ALUN	
	32	040724	FL032ALUN	
	40	040725	FL040ALUN	
	50	040726	FL050ALUN	
	63	040727	FL063ALUN	
	80	040728	FL080ALUN	
	100	040729	FL100ALUN	

Screws to be ordered separately, see from page 1.101.40

Flange in steel FL..AQUN

 	For cylinder Ø mm	Code	Item	Compliance
	12-16	040751	FL012016AQUN	UNI TOP
	20	040752	FL020AQUN	
	25	040753	FL025AQUN	
	32	040754	FL032AQUN	
	40	040755	FL040AQUN	
	50	040756	FL050AQUN	
	63	040757	FL063AQUN	
	80	040758	FL080AQUN	
	100	040759	FL100AQUN	

Screws to be ordered separately, see from page 1.101.40

Rear 90° hinge in aluminium* with screws ASV..ALIS+V

	For cylinder Ø mm	Code	Item	Compliance
	32	042081	ASV032ALIS+V	
	40	042082	ASV040ALIS+V	
	50	042083	ASV050ALIS+V	
	63	042084	ASV063ALIS+V	
	80	042085	ASV080ALIS+V	
	100	042086	ASV100ALIS+V	

*Available also in steel: item CF..+P for Ø 12 ÷ 25 and item ASV..AQIS for Ø 32 ÷ 100, see page 1.100.153

Pin with seeger in steel SEC..AQIS

	For cylinder Ø mm	Code	Item	Compliance
	32	040261	SEC032AQIS	
	40	040262	SEC040AQIS	
	50	040263	SEC050AQIS	
	63	040264	SEC063AQIS	
	80	040265	SEC080AQIS	
	100	040266	SEC100AQIS	

*Supplied with 2 seeger

Low foot* in steel PB..AQUN

	For cylinder Ø mm	Code	Item	Compliance
	12-16	040761	PB012/016AQUN	
	20	040762	PB20AQUN	
	25	040763	PB25AQUN	
	32	040764	PB32AQUN	

*Supplied individually.
Screws to be ordered separately, see from page 1.101.40

Low foot* in steel PB..AQUN

	For cylinder Ø mm	Code	Item	Compliance
	40	040765	PB040AQUN	
	50	040766	PB050AQUN	
	63	040767	PB063AQUN	
	80	040768	PB080AQUN	
	100	040769	PB100AQUN	

*Supplied individually.
Screws to be ordered separately, see from page 1.101.40

Magnetic reed switch T groove ASV..

	For cylinder Ø mm	Code	Item	Cylinder matching
	12 ÷ 100	070946	ASV1C525	
		071863	ASV1C550	
		071864	ASV1C51K	
		071189	ASV1C5M8	
		073639	ASV4D225	
		070246	ASV4D2M8	
		070247	ASV7N2M8	
		070372	ASV7M2M8	
		072918	ASV1H525	

ATEX magnetic reed switch T groove MK..

	For cylinder Ø mm	Code	Item	Compliance	Cylinder matching
	12 ÷ 100	071120	MK500A		
		071108	MK502A		

